

## TECHNICAL BULLETIN 43'3 Tankmaster Tank Chassis

### Characteristics

Carries one 20 ft ISO Container. Meets all DOT, FMVSS, ANSI, SAE and TTMA specifications in effect at the time of chassis manufacture and applicable to operation in the United States.

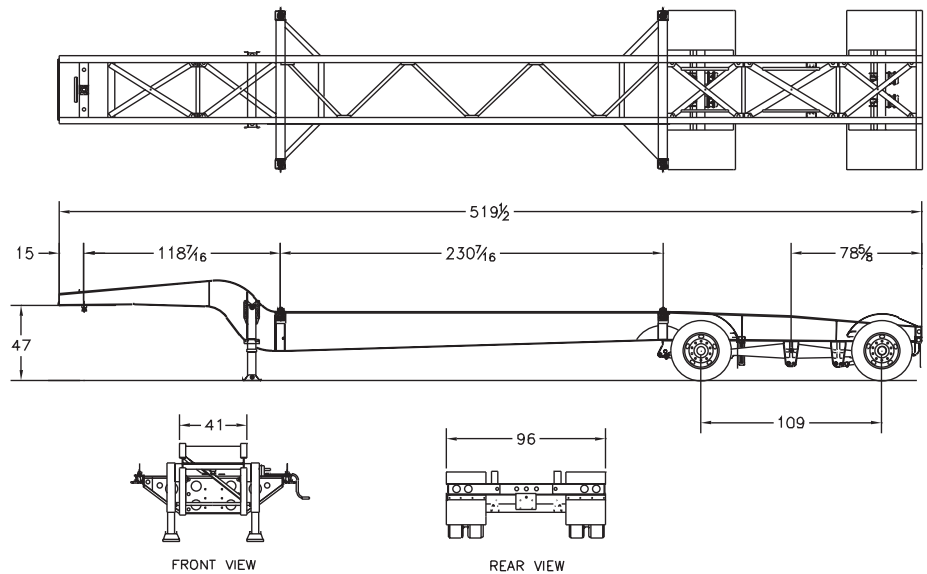

### ● DIMENSIONS

**Overall Chassis Length:** 43 ft. 3 in.

**Overall Chassis Width:** 96 inches

**Tandem Location:** 78 5/8 inches

**Kingpin Location:** 15 inches

**Frame Height at Container:** 41 1/2 inches

**Main Beams:** Fabricated I-Beam Tapered at rear

**Crank Handle Location:** Road side handle

**Suspension:** Hutch

**Axle Quantity:** Two Axles

**Suspension Type:** Spring-Ride

**Axle Centers:** 109 inch

**Springs:** Two Leaf

**Hub Type:** Hub piloted for disc wheels

**Hub Material:** Steel

**Drum:** Outboard mounted

**Rim/Wheels:** 8 1/4 X 22.5 hub piloted tubeless

**Wheel/Rim Color:** White

**Tire Size:** 255/70R 22.5

